

Performance test of a carbon dioxide heat pump for combined domestic hot water and floor heating

Eiji Hihara, Hirofumi Ida, Japan

Introduction

Japanese companies were the first to succeed in the commercialisation of a heat pump for domestic hot water heating, in which carbon dioxide is used as a refrigerant. As shown in Figure 1, sales of heat pumps have been steadily rising. In recent years, several types of multi-functional heat pumps that provide hot water, floor heating, or bathroom heating have been introduced on the Japanese market. However, no method for testing these multi-functional heat pumps has yet been established. It is difficult to decide a suitable test standard for these heat pumps in a reasonable and easy manner because of the diversities in their use by family members and household structures. In order to establish a new standard for measuring annual energy consumption of multi-functional heat pumps, they were subjected to several tests for combined domestic hot water and floor heating. This research was carried out as part of Annex 28 of the IEA Heat Pump Program.

Testing facility and the heat pump

The calorimetric chambers of the artificial environment laboratory at the R&D centre of the Tokyo Electric Power Company were used for the testing. The heat transferred by the heat pump being tested was measured by employing the air-enthalpy method, which measures the temperature and humidity of outdoor and indoor air and the air flow rates.

In order to measure the performance of the heat pump for combined domestic hot water and floor heating, the testing apparatus shown in Figure 2 was set up in the calorimetric chambers. The tap water was con-

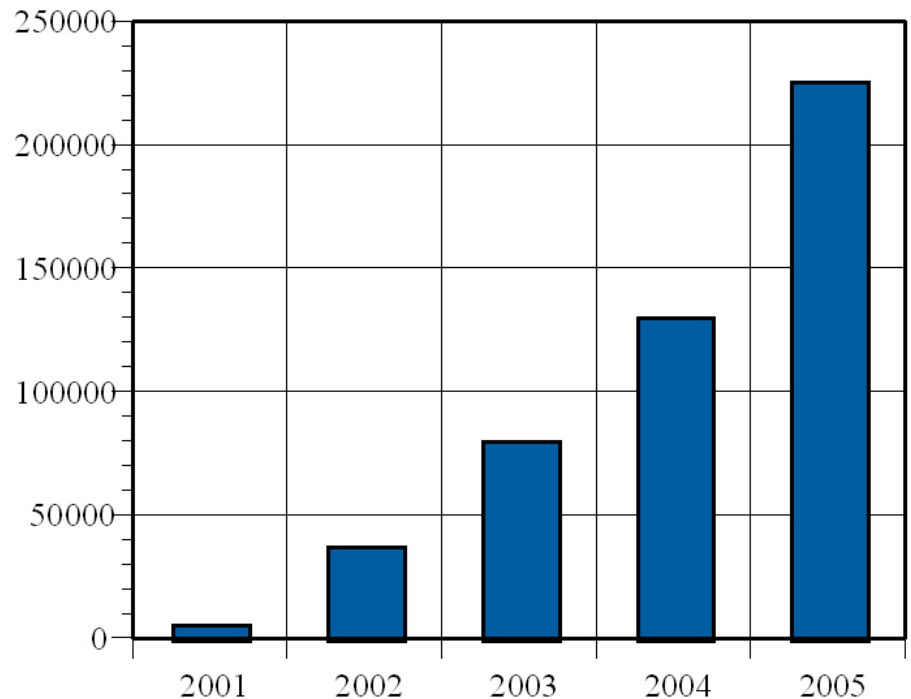

Fig.1 Shipment of CO₂ heat pump water heaters in Japan

trolled at a prescribed temperature by the flow-control unit, and its pressure was maintained at 200 kPa. The outflow of hot water from the hot water tank was regulated by a solenoid valve using a sequence timer. Cold water was supplied to a plate-type heat exchanger to simulate the floor heating load, which was regulated by measuring the flow rate and temperature change of cold water.

The heat pump tested for combined space heating and domestic hot water heating was manufactured by Denso Corporation and was available on the market. Its specifications are shown in Table 1. The heat pump system consists of a heat pump unit and hot water storage unit. The heat pump runs during the night, and the hot water produced is stored in the tank.

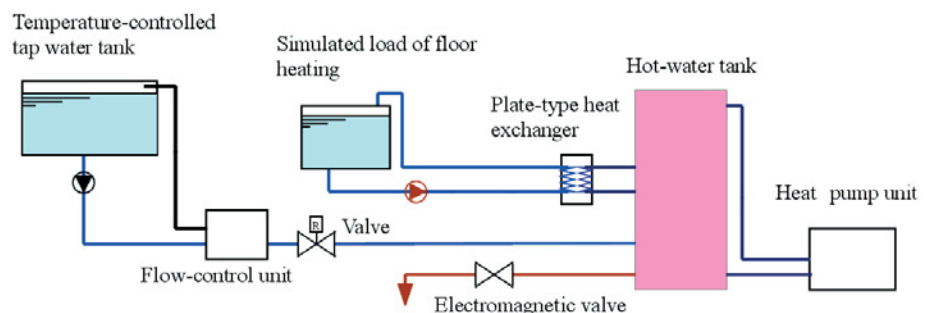

Fig.2 Schematic diagram of the testing apparatus

The heat pump seldom needs to run during the day since the cost of electricity is less during the night.

Testing method

The method employed for testing the heat pump unit excluding the hot-water storage unit is described in JRAIA Standard JRA4050:2005. The temperature conditions of outdoor air and cold water supply are summarized in Table 2. The compressor was operated at a constant speed during the test according to the test conditions, except during the defrosting test.

The typical draw-off profile for the house of a standard family is proposed by the Institute for Building Environment and Energy Conservation in Japan, and is shown in Table 3. Based on the meteorological data for Tokyo district, the number of days that witnessed an increased heating load during summer, winter, and the intermediate season were 92, 120, and 153, respectively.

No standard for the floor heating load for Japanese houses or apartments has yet been established. In this study, assuming a typical family house, the heat demand for floor heating in houses was calculated using a heat-load calculation program. The Architectural Institute of Japan considers a standard house for discussing thermal environmental problems. In Japanese houses, central air conditioning systems are not popular; instead, each room is individually air-conditioned. We assumed that the living and dining rooms are equipped with floor-heating panels, with an area of 20.49 m². The remaining areas of the house are not air-conditioned by this heat pump system. The temperature of the floor surface is maintained at 30 °C by the hot water, which is equivalent to an indoor temperature of 20 °C. The patterns of the heating load during an average day, cold day, and warm day are assumed. Figure 3 shows the pattern for an average day.

Table 1 Specifications of the tested heat pump

Working fluid in the heat pump	Carbon dioxide
Tank capacity	460 l
Heating power	6.0 kW
Electric power input	1.4 kW
Hot-water temperature in the tank	Approximately between 65 °C and 90 °C (automatically controlled in response to hot water consumption)
Compressor	Variable-speed hermetic compressor
Size of the heat pump unit	640 mm(H), 820 mm(W), 300 mm(D)
Size of the hot-water storage unit	1890 mm(H), 720 mm(W), 800 mm(D)

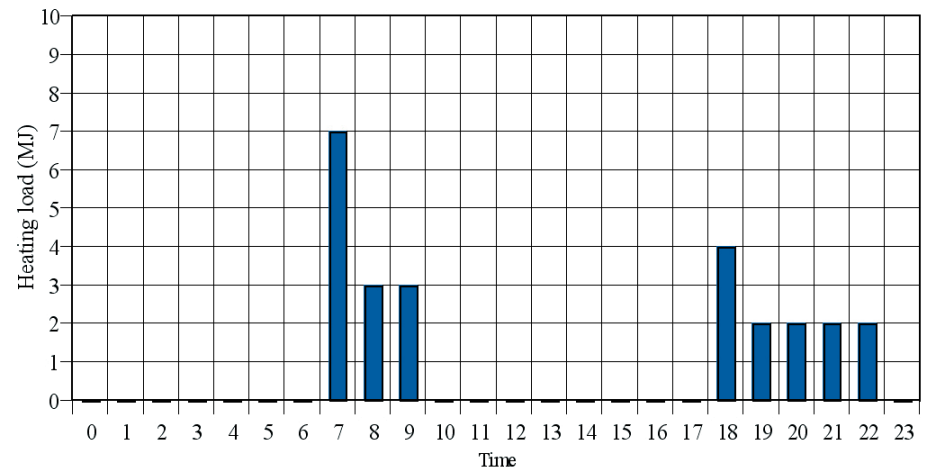

Fig.3 Floor heating demand pattern on an average day

Table 2 Temperature conditions

	Outdoor temperature		Temperature of the cold water supplied	Temperature of the outgoing hot water
	DB	WB		
	°C	°C	°C	°C
Rated heating condition	16	12	17	65
Heating condition during winter	7	6	9	90
Defrosting condition during winter	2	1	5	90
Heating condition during summer	25	21	24	65

Table 3 Draw-off profile

Time	Usage	Temperature of hot water	Temperature of tap water	Amount of hot-water supply			
				L			
600	Kitchen and lavatory	42°C	24°C in summer 17°C in intermediate seasons 9°C in winter	15.9			
630				15.9			
700				15.9			
730				15.9			
800				15.9			
1200				15.9			
1800				15.9			
1830				15.9			
1900				15.9			
1930				15.9			
2100				Bath	60°C	24°C in summer 17°C in intermediate seasons 9°C in winter	180
2130				Shower			40
2200	Additional use for bath	60°C		22			



Table 4 Heat load and electrical energy input

Season	Mode	Type of day	Number of days	Heat produced	Electrical energy input to the HP	Heat load	Total electrical energy input
				MJ/day	kWh/day	MJ/day	kWh/day
Summer	WH	-	92	39.81	2.33	33.04	2.64
Intermediate seasons	WH	-	123	54.83	3.61	45.66	3.93
	WH & FH	Warm day	30	78.14	5.81	59.58	6.12
Winter	WH & FH	Average day	108	112.46	10.24	90.23	10.56
	WH & FH	Cold day	12	128.86	13.15	103.55	14.68

Test results

The results of the seasonal performance test of the combined hot water and floor heating operation are shown in Tables 4 and 5. The difference between the heat produced by the heat pump unit and the heat load is 18.9 % of the total heat produced. The reason why the heat loss from the hot water storage unit is large is that all the water in the tank is heated at 70 °C in the combined water heating (WH) and floor heating (FH) mode. The result on the overall seasonal efficiency of this combined mode is lower than that of the hot-water-heating-only mode. This efficiency can be improved by modifying the management of hot water in the tank.

Table 5 Seasonal performance of the combined hot water and floor heating mode

Heat produced by the HP, GJ/year	26.4
Electrical energy input to the HP, MWh/year	2.10
Heat load, GJ/year	21.4
Total electrical energy input, MWh/year	2.23
Seasonal efficiency of the HP unit	3.5
Seasonal efficiency of the overall system	2.7

Conclusion

A brand new heat pump for combined water and floor heating was tested to investigate the method for testing its seasonal performance. Depending on the system configuration, the heat pump operates in various ways. Further, a wide variety of floor heating panels are available. Therefore, the method for testing the efficiency of floor and water heating pumps should be specified by the parameters at the system boundary. The draw-off profile and patterns of the floor-heating demand for each season should be determined and the test operation should be performed in accordance with these profiles.

Eiji Hihara

University of Tokyo

Hirofumi Ida

Tokyo Electric Power Company

